



Tetley Technology (HK) Ltd

泰莱科技（香港）有限公司

Tetley Technology (HK) Ltd



Solenoid Pump Expert

SHOW



Solenoid Pump

- Miniature size, low temperature.
- Apply on kinds of acid/alkali mediums.
- High reliability.

公司概况 COMPANY PROFILE

Tetley Technology (HK) Limited 泰莱科技(香港)有限公司	P02
Tai Mao Metal & Plastics Co.,Ltd. 泰茂塑胶五金有限公司	P03-P04
Tetley Springs & Metal Co., Ltd. 泰莱弹簧五金有限公司	P05-P06

核心产品 CORE PRODUCTS

Micro Solenoid Pumps 微型电磁泵	P07-P16
-------------------------------	---------

TLM Series P07-P08

TLH Series P09-P10

TLF Series P11-P12

TLP Series P13-P14

TLMS Series P15

TLR Series P16

DC Motor Pumps 微型直流泵	P17-P18
-------------------------	---------

Water Pumps > TLA Series

Air Pumps > TLW Series

Valves 电磁阀	P19
---------------	-----

TLDV-1

TLDV-3

TLDV-4

Accessories Center 配件中心	P20
----------------------------	-----

公司荣誉 COMPANY HONOR

Application 产品应用范围	P21
Company qualification certification 公司资质认证	P22

Company Introduction

公司介绍

Tetley Technology (HK) Limited was established in 1998, specializing in micro-pump, valve and precision components, plastics parts development and sales. Tetley Technology has sales network in the US, Europe, Japan and Korea. Tetley Technology is comprising of 2 companies, namely Tetley Springs & Metal Co., Ltd., Tai Mao Metal & Plastics Co., Ltd. They are located in the key manufacturing cities of Dong Guan, in southern China province of Guang Dong. Tetley Technology have a Sales office in Canada responsible for sales in the US and Europe.

泰莱科技(香港)有限公司成立于1998年, 公司专注于泵类, 阀体及精密零部件、塑胶制品的研发和销售, 销售网络遍布欧美日韩。公司旗下在国内有2家制造工厂, 泰莱弹簧五金有限公司、泰茂五金塑胶有限公司, 分别位于中国制造业名城的东莞市常平镇及桥头镇。此外公司在加拿大也设立了分公司, 主要负责公司在欧美地区的销售。





Tai Mao Metal & Plastics Co., Ltd.

was established in 2005 as the second factory in Dong Guan for Tetley Technology (HK) Limited. Tai Mao has the following production lines: precision metal parts, precision plastics injection, mold making and a Clean Room for assembly and can also do OEM/ODM. Tai Mao specializes in developing and manufacturing of precision micro-pumps, plastics valves and metal parts, exporting to the US, Europe, Japan and Korea. All products have UL/TUV accreditation, and also meet FDA food contact and RoHS/PAHS/REACH requirements, Tai Mao focus on being a NSF approved supply system.

Tai Mao, besides having its own core technologies, has an excellent engineering team exceeding 20 members, more than 50% of the design engineers graduated from top universities in China. The development team members all have greater than 10 years experiences in design and development of electronic and plastics parts. Tai Mao can provide design/development solutions according to customer's own individual requirements. Tai Mao will integrate "innovation, encompassing, green, energy saving" concepts into the manufacturing of products in order to achieve global reduction in energy and carbon dioxide emission level.

Tai Mao also has a very competent quality system, advance quality testing equipment and well trained and highly experienced quality team. Strict control over every step in manufacturing is implemented in the products. SPC is used in manufacturing process and other statistical tools such as cpk, ppk, x-r chart and MSA analysis etc. to ensure products can meet customers' requirements.

Tai Mao also emphasizes on management and environmental protection and have been awarded ISO9000 and ISO14001, also the "Green Industry" title.

Core Products

- Micro Solenoid Pumps (TLM, TLH, TLF, TLP, TLMS, TLR).
- DC Motor Pumps (TLA, TLW) – Water Pumps, and Air Pumps.
- Valves – Bleed Valves, Check Valves, Solenoid Valves. (TLV, TLDV)



东莞泰茂五金塑胶有限公司 — 是泰莱科技（香港）有限公司于 2005 年在东莞桥头镇设立第二家制造工厂。公司下设精密五金车间 / 精密注塑车间 / 模具车间 / 无尘装配车间。同时具备OEM及ODM能力。主要以生产研发精密泵、阀塑胶五金制品为主，营销网络遍布欧美日韩等国。产品取得UL/TUV认证，同时还能满足FDA食品级要求及RoHS/PAHS/REACH等环保指令要求。我们专注于成为NSF产品认证供应体系。

泰茂公司拥有核心技术，并有一支20多位工程师组成的优秀设计研发团队，其工程设计研发人员50%毕业于国内顶尖大学，且所有研发团队人员均有超过10年以上塑胶电子产品之设计研发经验，能根据不同行业的客户需求提供全方位的设计研发方案。并以“创新、融合、绿色、节能”理念贯穿到整个产品生命周期。为实现全球性降低能耗和二氧化碳排放不懈努力。

同时公司有着完善的品质保证体系，先进的品质检验设备，及基础扎实经验丰富的品质队伍，对于产品生产的每一个环节都有严格的品质控制手段，并将系统的统计技术熟练的运用于生产过程、量测系统分析等，如CPK/PPK及X-R控制图，MSA研究等。确保产品质量最终能满足客户的需求。

泰茂公司同样重视管理关注环境，且也先后获取ISO9000/ISO14001等质量环境体系认证，同时也获得“绿色企业称号”。

核心产品

- 微型电磁泵 规格有: (TLM\TLH\TLF\TLP\TLMS\TLR)
- 直流泵 规格有: (气泵TLA) / (水泵TLW)
- 阀 (节流阀、单向阀、电磁阀): (TLV/TLDV)

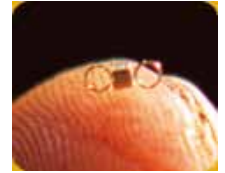
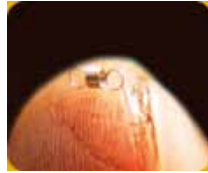
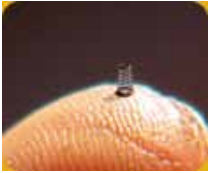

Tetley Springs & Metal Co.,Ltd.(TSM)

was established by Tetley Technology (HK) Limited in 1999 as her first factory. The major products are precision springs and stamping of metals. TSM is equipped with advanced CNC machines and a team of technical staff with more than 20 years experiences. All products are applied in the electronic,electrical appliance, automotive and medical sectors and mainly exported to Europe, US, Japan and Korea. Paying a lot of attention to quality, management and environment, TSM has hence been accredited to ISO9000, ISO/TS16949.2002 and ISO14001. All products meet the RoHS/REACH requirements and have been awarded “Green Industry” title as well.

Major Products

- Precision springs: compression springs, torsion springs, tension springs, wire forms.
- Wire diameter ranges from 0.08 mm to 8.00 mm
- Shaft: solenoid, electrical motors and electronic industry
- Metal stamping

Applications

- Electronic industry: switches, battery contacts, mobile phones, antenna,
- Electrical appliance industry: washing machines, dryers, shavers, steaming machines, liquid dispenser, water drinking machines,
- Automotive industry: brake system, clutch, spring in shock absorbers, safety belt system,suspension springs

Core values

- Tetley has a dynamic culture that encourages continuous improvements embracing the following core values:
 - Quality and innovation
 - Freedom with accountability
 - Customer focus and long-term view
 - Partnership and fun



泰莱弹簧五金制品厂

是泰莱科技（香港）有限公司于 1999 年在东莞常平设立第一家工厂，以制造精密弹簧冲压件为主，拥有先进精密自动成型数控设备，并有一支超过20年以上行业经验的技术队伍。客户群体遍布电子电器、汽车、玩具、医疗等行业，产品出口欧美日韩等国家。公司重视管理，关注环境，先后获得ISO9000质量管理体系认证，ISO/TS16949:2002汽车行业质量管理体系认证及ISO14001环境体系认证，公司所生产的产品均能符合RoHS/REACH等环保指令要求，获得“绿色企业”称号。

主要产品

- 精密弹簧有：压簧、扭簧、拉簧、线成形，线径范围： $\phi 0.08\text{mm} \sim \phi 8.00\text{mm}$ 。
- 轴：用在玩具、马达和电子产品上。
- 五金冲片。

应用范围

- 电子行业：开关弹簧、电池弹簧、天线弹簧、手机……
- 电器产品：蒸气机、饮水机、液体喷雾机、干燥机……
- 汽车工业：刹车系统、离合器、减震器弹簧、安全带……

核心价值观

泰莱有一种动力文件激励员工不断改进，主要包含以下核心价值观

- 质量和创新 • 责任自主
- 客户至上和长远的发展观 • 团结合作和良好的工作气氛



▶ Micro Solenoid Pumps

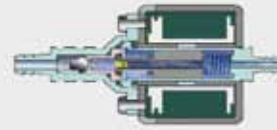

TLM Series

ED: Continuous	Basic Configuration			Power
	Specification	Low	High	
	Max Pressure(bar)	1.5	4.5	
Flow rate @ 0 Bar	50	220		
Model	Average	Flow rate @ 0 Bar		16
TLM-1	65	50	80	
TLM-2	100	80	120	
TLM-3	145	120	170	
TLM-4	195	170	220	



Mechanical Drawing & Dimension
机械制图及尺寸

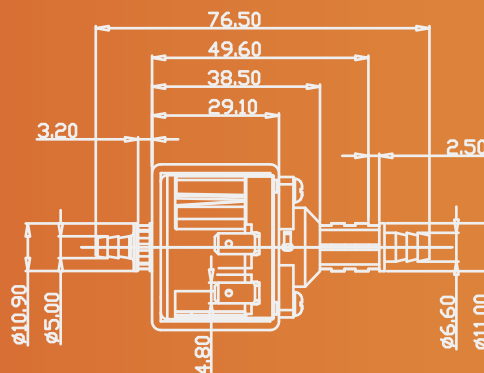

TLM-1

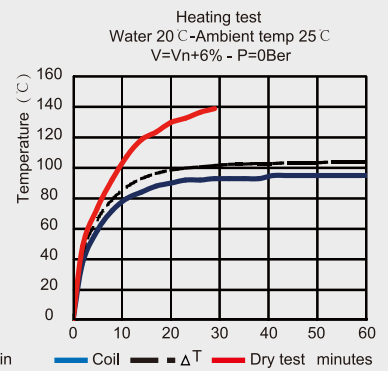
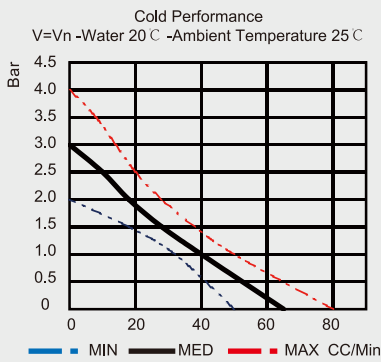
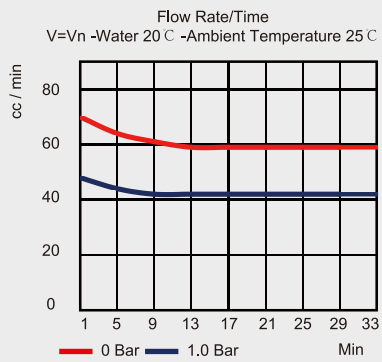

TLM-2

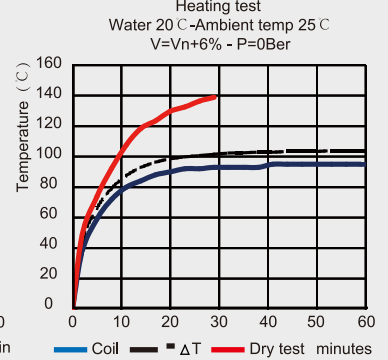
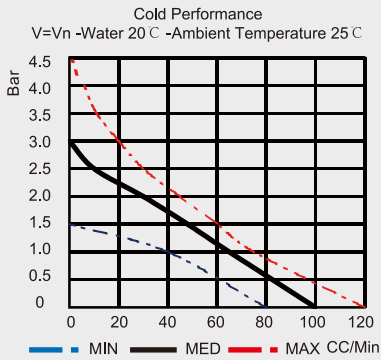
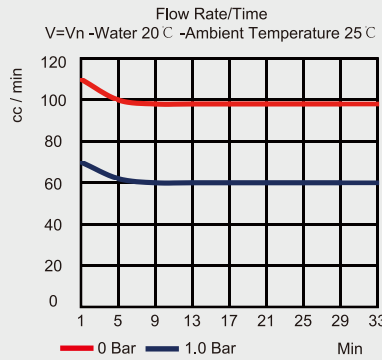

TLM-3

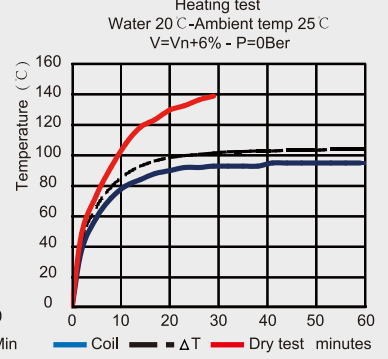
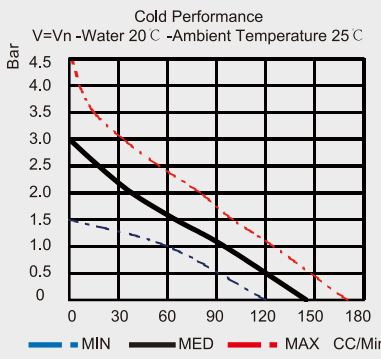
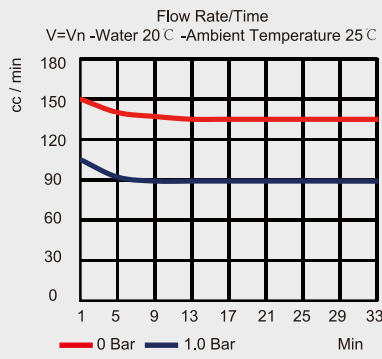

TLM-4

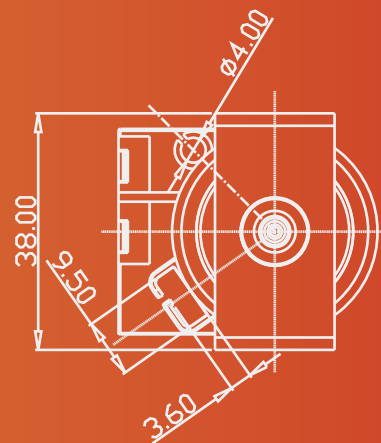
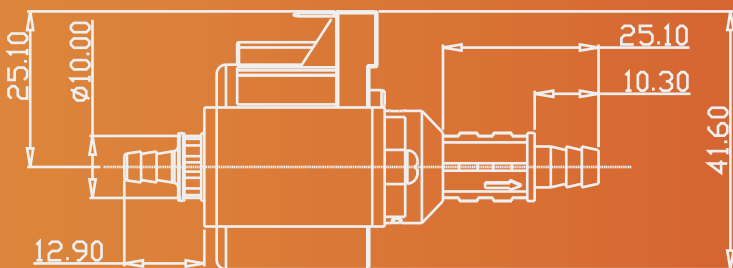
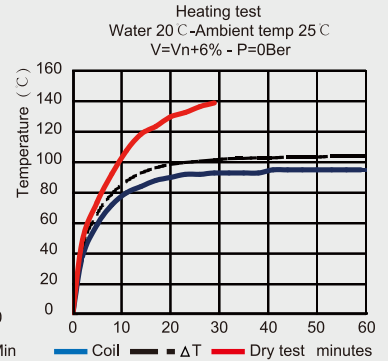
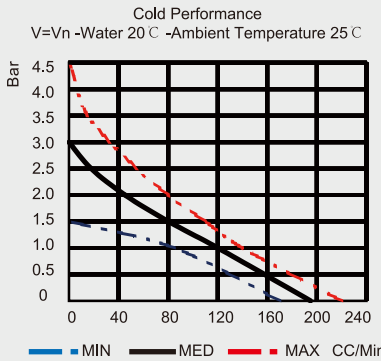
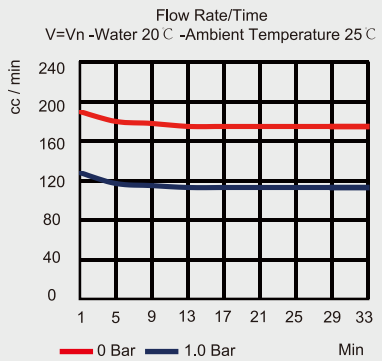

Tol. +/-0.3mm

Micro Solenoid Pumps

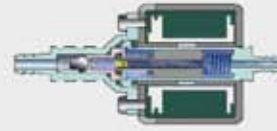

TLH Series

ED: Continuous	Basic Configuration			Power
	Specification	Low	High	
	Max Pressure(bar)	4	7	
Flow rate @ 0 Bar	80	550		
Model	Average	Flow rate @ 0 Bar		21
TLH-1	100	80	120	
TLH-2	140	120	160	
TLH-3	180	160	200	
TLH-4	225	200	250	
TLH-F	450	350	550	



TLH-1

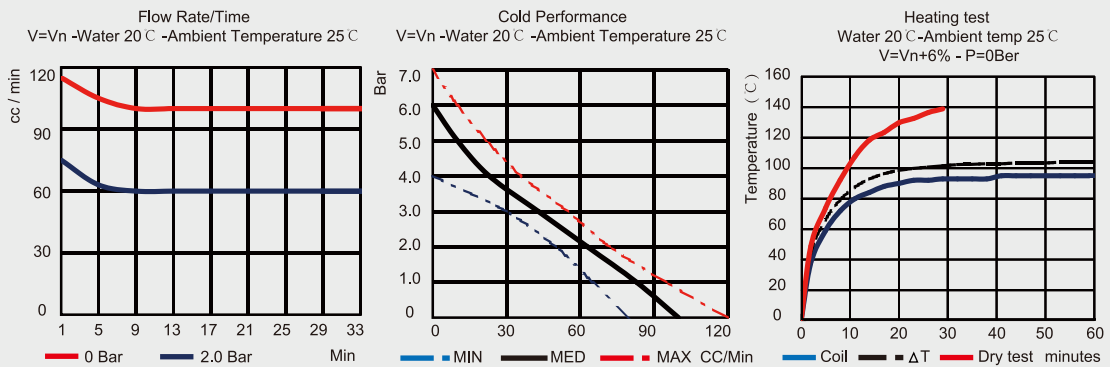

Mechanical Drawing & Dimension

机械制图及尺寸

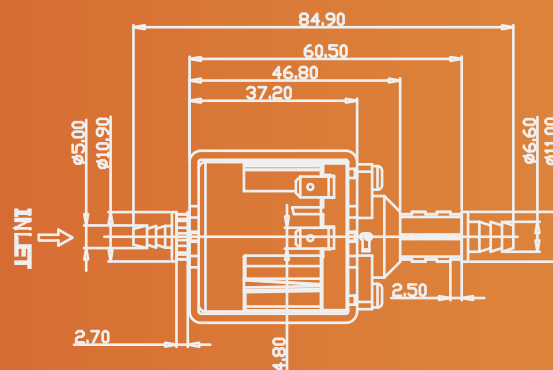

TLH-2

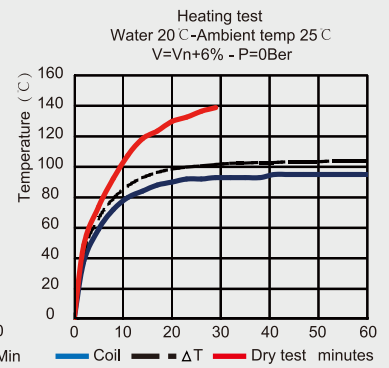
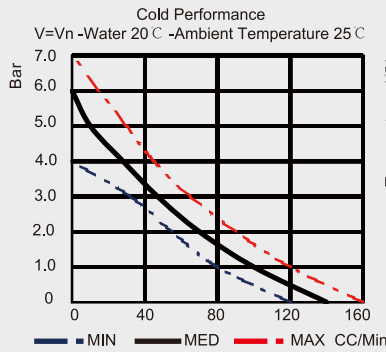
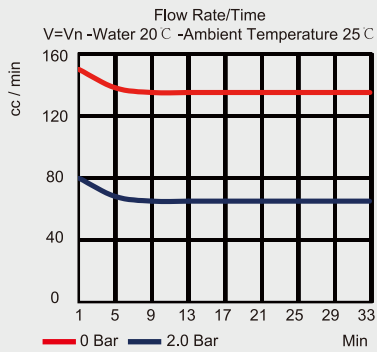

TLH-3

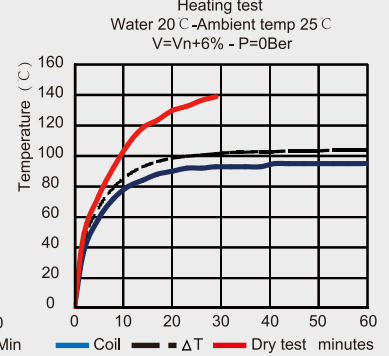
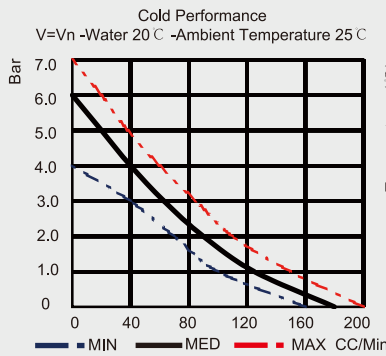
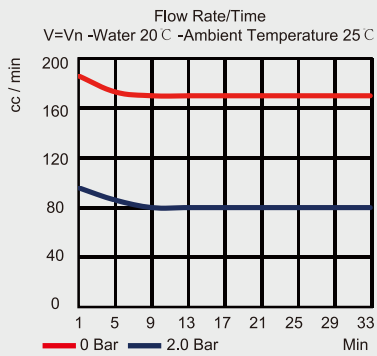

TLH-4

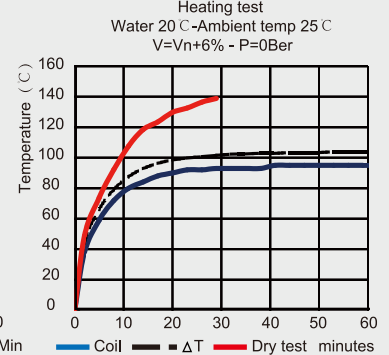
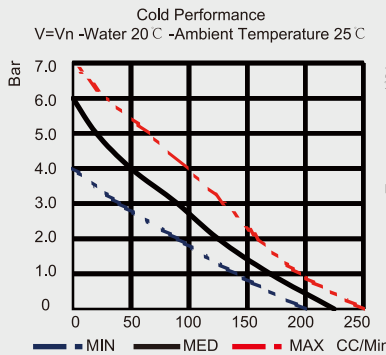
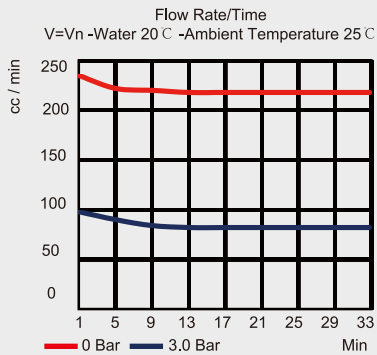

TLH-F

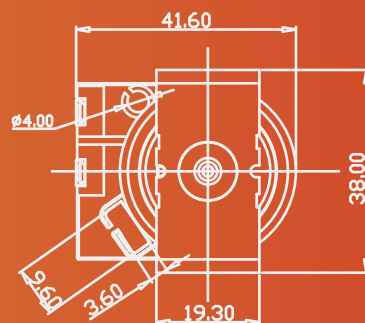
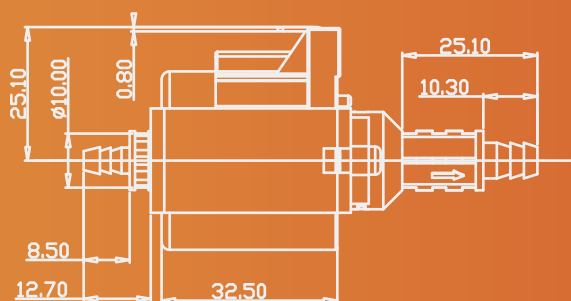
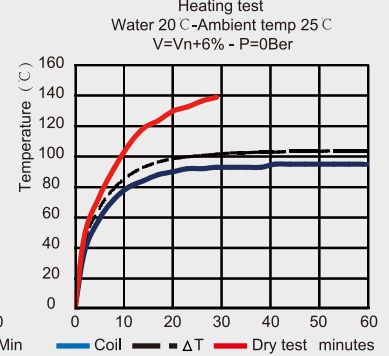
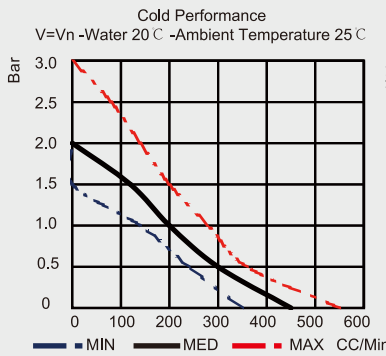
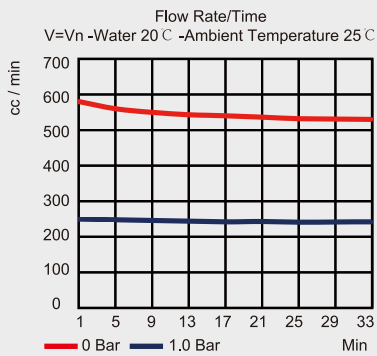

Tol. +/-0.3mm

▶ Micro Solenoid Pumps

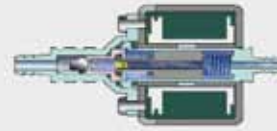

TLF Series

ED: On 2 off 1	Basic Configuration			Power
	Specification	Low	High	
	Max Pressure(bar)	1	3	
Flow rate @ 0 Bar	450	950		
Model	Average	Flow rate @ 0 Bar		25
TLF-1	575	450	700	
TLF-2	825	700	950	



Mechanical Drawing & Dimension
机械制图及尺寸

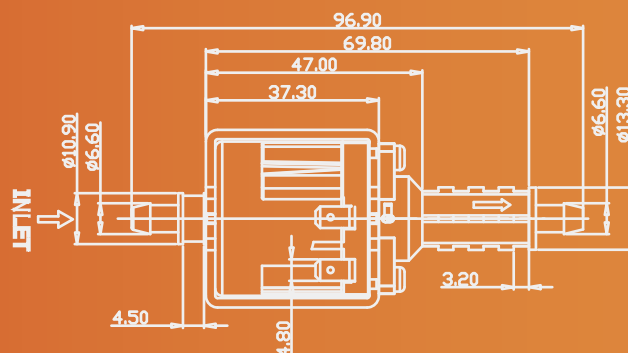

TLF-1

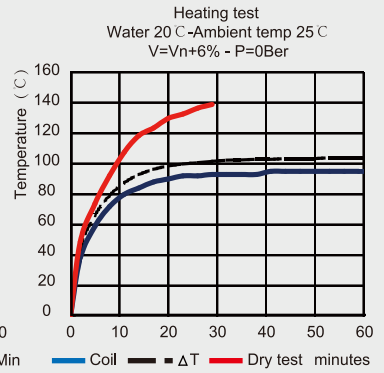
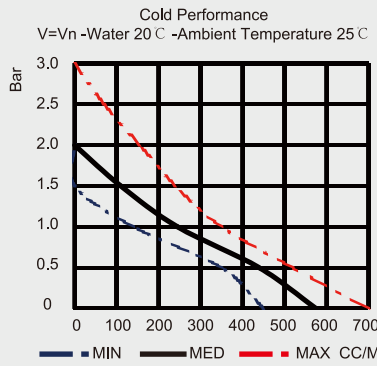
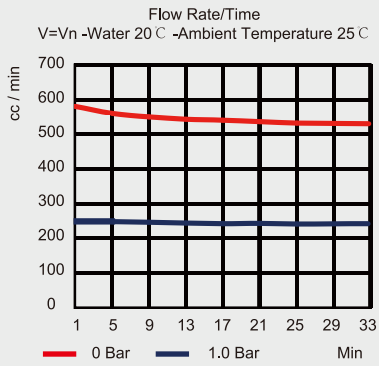

TLF-2

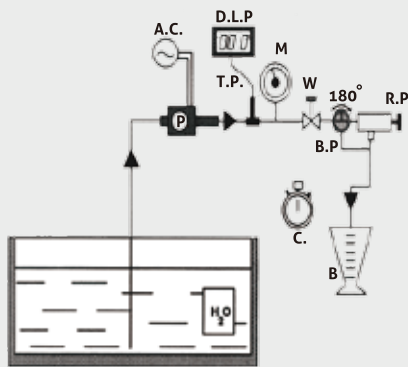
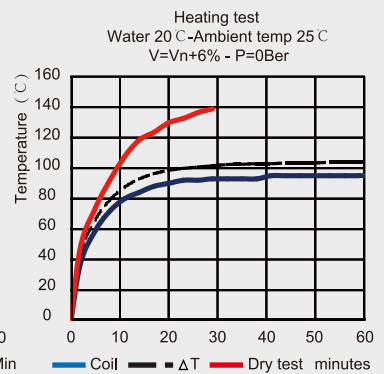
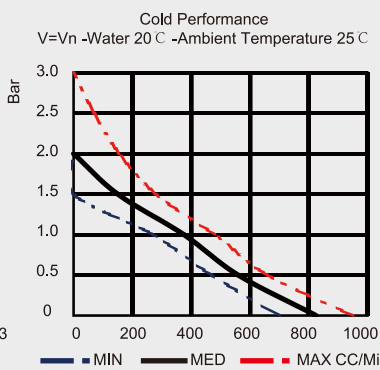
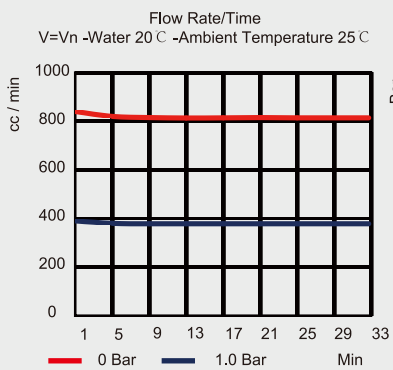

HOW OUR TEST IS CARRIED OUT:

- 1-COLD PUMP
- 2-"X" PRESSURE VALUE SETTING
- 3-RATE OF FLOW MEASURED IN 1 MINUTE (B)

LEGEND:

- P. =Pump
- A.C =Pump supply at V=Vn
- T.P. =Pressure electronic transducer
- D.L.P.=Pressure reading display
- M =Manometer with glycerine inside
- B.P. =By-Pass at 0 Bar
- R.P. =Pressure setting regulator
- C. =Chronometer
- B =Flow Rate measurement container (becker)
- W =Water tap to measure the maximum pressure

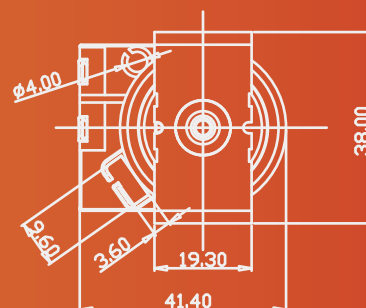
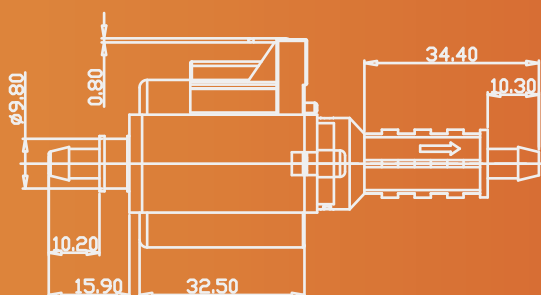

Tol. +/-0.3mm

▶ Micro Solenoid Pumps

TLP Series

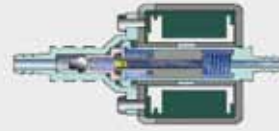

ED: On 2 off 1	Basic Configuration			Power
	Specification	Low	High	
	Max Pressure(bar)	8	24	
	Flow rate @ 0 Bar	350	750	
Model	Average	Flow rate @ 0 Bar		
TLP-4	450	350	550	50
TLP-5	650	550	750	
ED: Continuous	Basic Configuration			Power
	Specification	Low	High	
	Max Pressure(bar)	3	10	
	Flow rate @ 0 Bar	700	1300	
Model	Average	Flow rate @ 0 Bar		
TLP-8	850	700	1000	35
TLP-9	1150	1000	1300	



Mechanical Drawing & Dimension 机械制图及尺寸

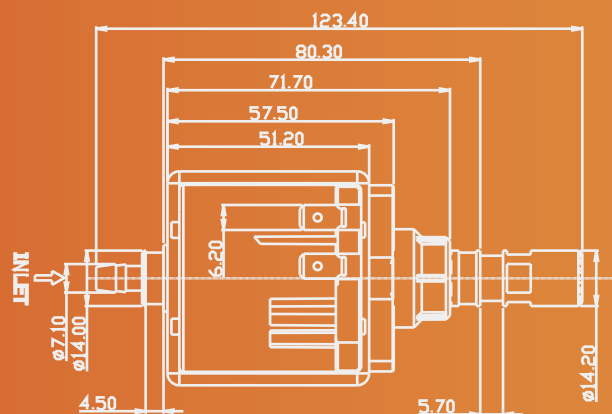

TLP-4

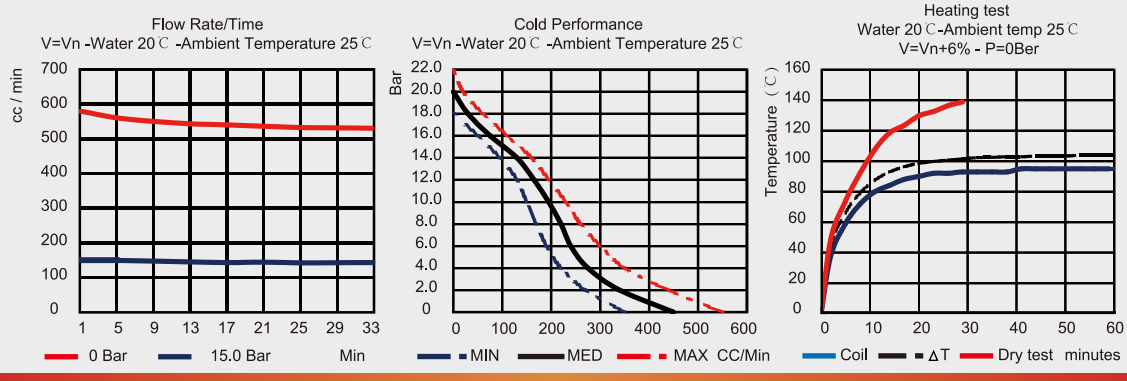

TLP-5

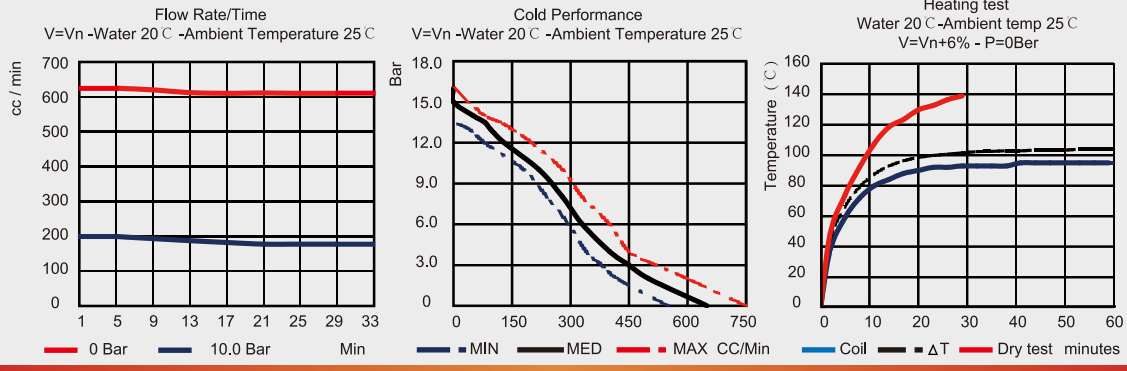

TLP-8

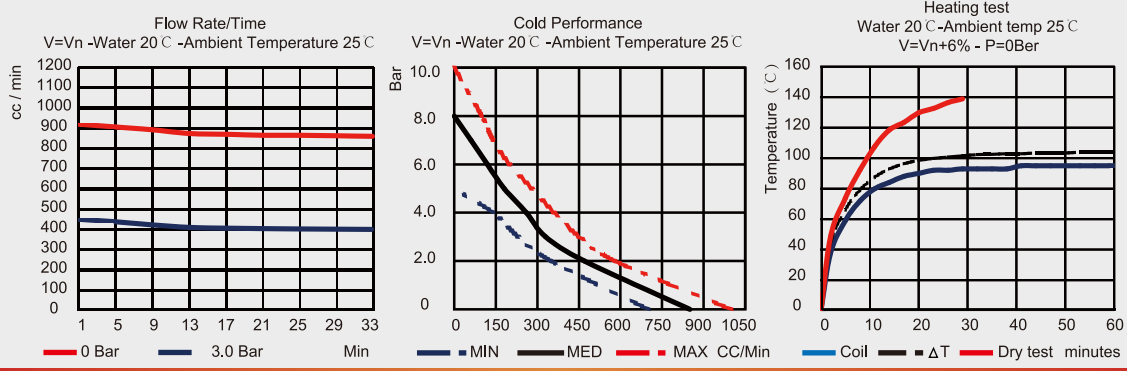

TLP-9

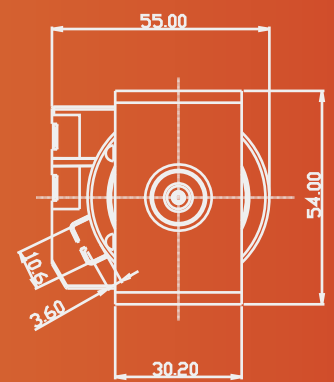
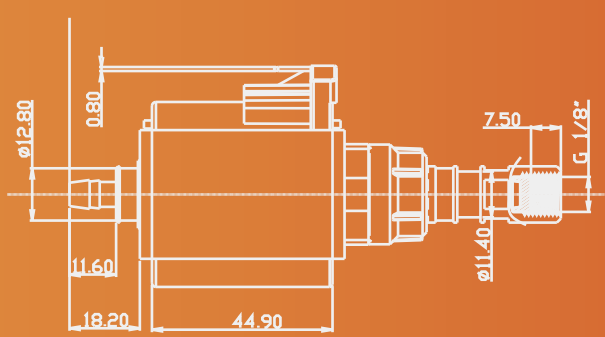
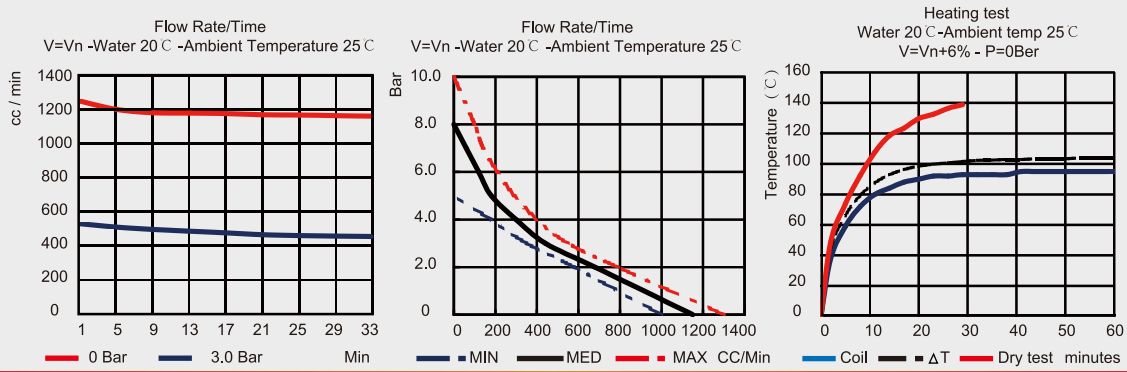

Tol. +/-0.3mm

▶ Micro Solenoid Pumps

TLMS Series

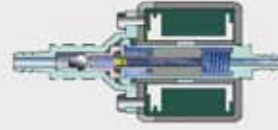

ED: Continuous	Basic Configuration			Power
	Specification	Low	High	
	Max Pressure(bar)	0.2	0.5	
Flow rate @ 0 Bar	15	50		
Model	Average	Flow rate @ 0 Bar		
TLMS-S TLMS-E	32.5	15	50	9



Cold Performance
V=Vn -Water 20 C -Ambient Temperature 25 C

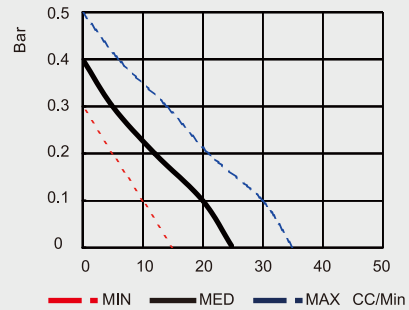

Mechanical Drawing & Dimension 机械制图及尺寸

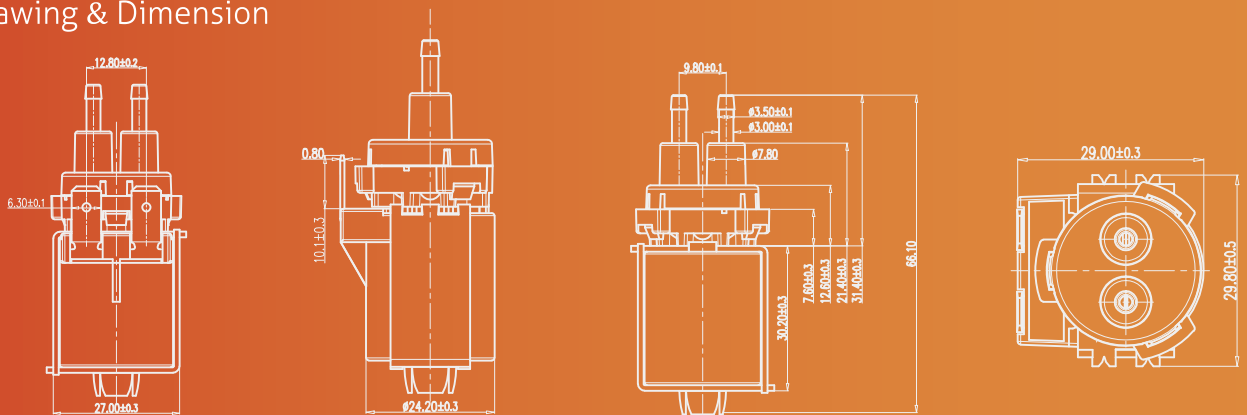

▶ Micro Solenoid Pumps

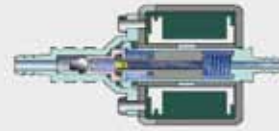

TLR Series

ED:	Basic Configuration			Power
	Specification	Low	High	
	Continuous	Max Pressure(bar)	2	
	Flow rate @ 0 Bar	50	250	
Model	Average	Flow rate @ 0 Bar		18
TLR-S	150	50	250	
TLR-E	150	50	250	
TLR	150	50	250	

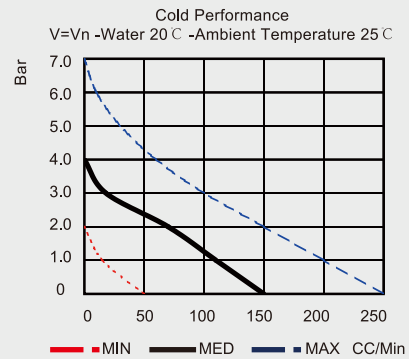

Mechanical Drawing & Dimension 机械制图及尺寸

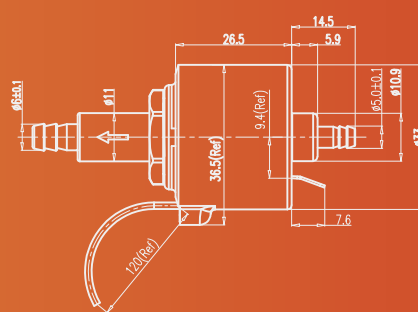
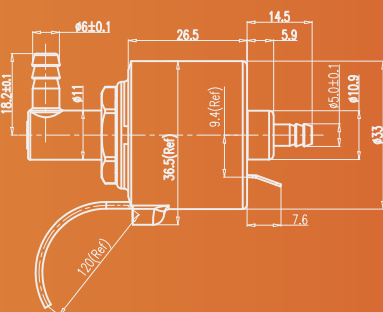

OR

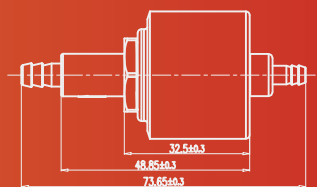
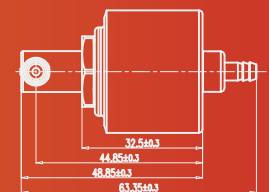

▶ DC Motor Pumps

Water Pumps>> **TLW Series**



ED:	Basic Configuration			Voltage
	Specification	Low	High	
	—	Max Pressure(bar)	1	
	Flow rate @ 0 Bar	300	2500	
Model	Average	Flow rate @ 0 Bar		6V/12V24
TLW-11	400	300	550	
TLW-12	625	550	700	
TLW-13	775	700	850	
TLW-14	1850	1200	2500	

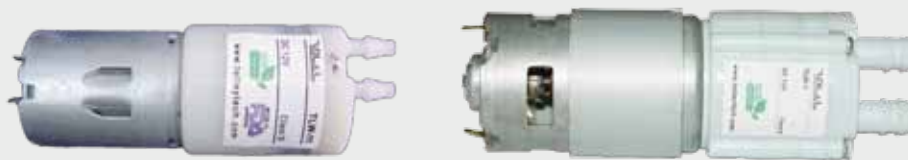

Mechanical Drawing & Dimension
机械制图及尺寸

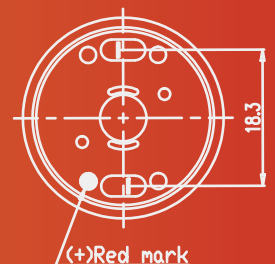
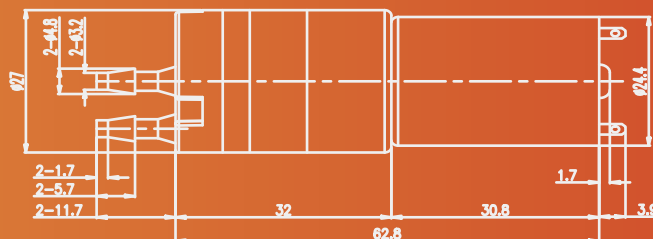

▶ Valves

TLDV

Model	Voltage(DC)	Flow rate (cc/min)	Max pressure(Bar)	Current(mA)
TLDV-1	12V/24V	1300	0.5~1.0	0.6 (Ref)
TLDV-3	12V/24V	1100	0~0.8	
TLDV-4	120V/230V	900	0~1.5	



Mechanical Drawing & Dimension
机械制图及尺寸

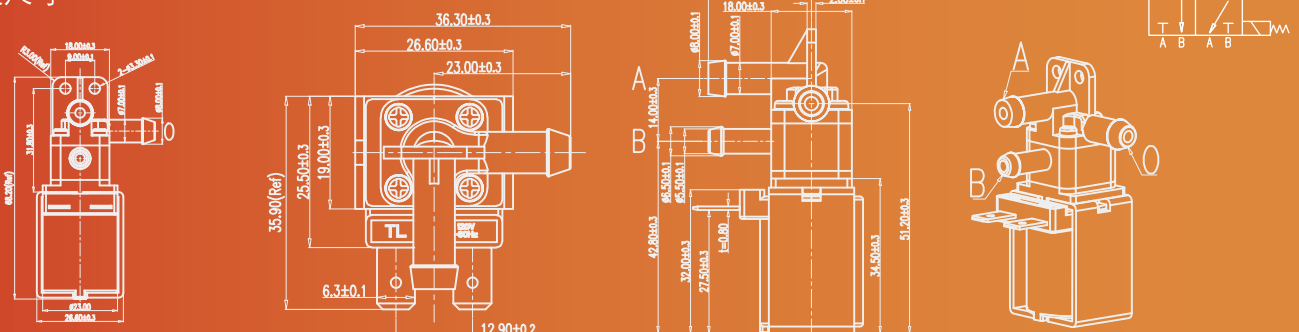

▶ Accessories Center

配件中心



Frequency modulation control board
调频控制板

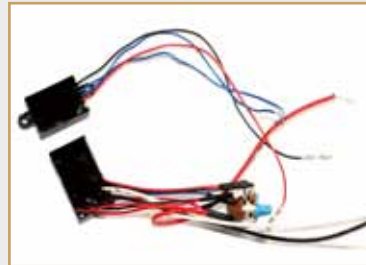

Frequency modulation control board
调频控制板



Relief valve
泄气阀



Check valve
单向阀



Safety and relief valve
安全阀/泄压阀

[参数功能 / Functions]

Those supporting accessories are used together with solenoid pumps, and valves. They are indispensable accessories for customer's products to realize the various functions.

此系列电磁水泵/阀周边配件，是对应配合客户产品实现各种功能的必需零件，我们以优良的品质，一致性，为客户提供最佳的配合/配件服务。

▶ Standard pumps for Electrical Appliances

Applying For 产品范围	Model Nr. 型号	Voltage 电压 Frequency 频率	Max Pressure 最大压力 (bar)	Flow rate @ 0 bar 空载流量 (ml/min)
	TLF-2	120V 60Hz	1.0-3.0	700-950
	TLP-4	220-240V 50/60Hz	8.0-24.0	350-550
	TLM-1	120V 60Hz	1.5-4.5	50-80
	TLR	220-240V 50/60Hz		
	TLM-4	120V 60Hz	1.5-4.5	170-220
	TLH-4		4.0-7.0	200-250
	TLP-5	220-240V 50/60Hz	8.0-18.0	550-750
	TLM-4	120V 60Hz	1.5-4.5	170-220
	TLH-F	220-240V 50/60Hz	1.0-3.0	350-550
	TLM-4	220-240V 50/60Hz	1.5-4.5	170-220
		120V 60Hz		
	TLH-4	120V 60Hz	4.0-7.0	220-250
	TLP-5	220-240V 50/60Hz	8.0-18.0	550-750
	TLH-F	120V 60Hz	1.0-3.0	350-550
		220-240V 50/60Hz		
	TLW-11	DC 5V	0.5-2.0	300-1300
	TLA-13	DC 12V、DC24V	0.5-3.0	800-1200
		6V、12V	0.5-3.0	40-100 100-200
	TLMS	120V 60Hz	0.2~0.5	15~35
		220-240V 50/60Hz		

Certificate 公司荣誉



ISO 9001:2008



ISO 14001:2004



绿色企业



ISO/TS 16949:2009

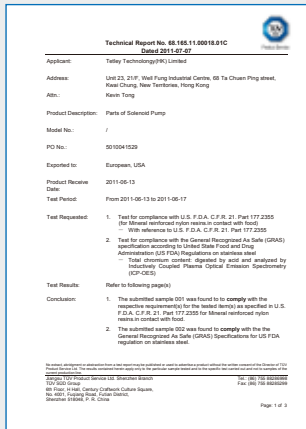

FDA 证书

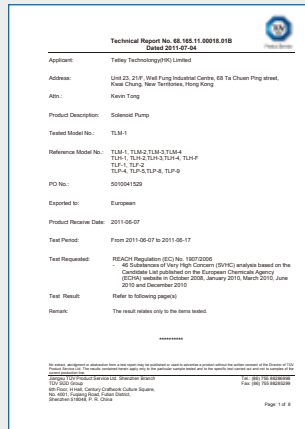

Reach 证书

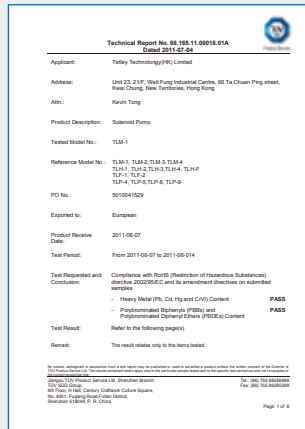

RoHS 证书

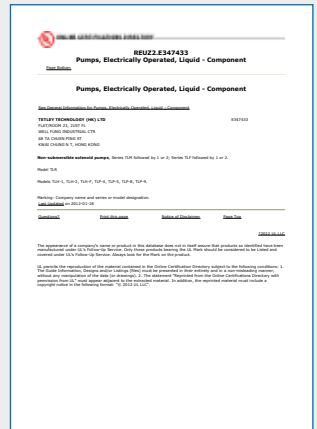

UL 证书

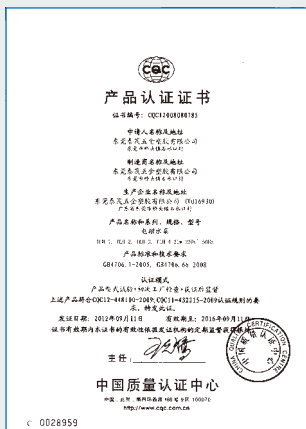

CQC 证书



TUV 证书



Tetley Technology (HK) Ltd

泰萊科技（香港）有限公司

Tetley Technology (HK) Ltd

- **泰萊科技(香港)有限公司**
Tetley Technology (HK) Limited

Tel : +852 2415 2885
Fax : +852 2415 3887
Email: info@tetleytech.com
Web: www.tetleytech.com

香港葵涌打磚坪街68號和豐工業中心21樓23室

Unit 23, 21/F., Well Fung Industrial Centre, 68 Ta Chuen Ping Street, Kwai Chung, New Territories, Hong Kong

- **Campi Springs Inc.**

Tel : + 514-425-4800
or 1-800-363-5372
Fax : + 514-425-4828
Email : info@campisprings.com

17 Huot N.D. Ile Perrot Quebec ,
Canada J7V 7M4

- **泰萊彈簧五金有限公司**
Tetley Springs & Metal Co., Ltd.
- **泰茂五金塑膠有限公司**
Tai Mao Metal & Plastics Co.,Ltd.

Tel : +86 769 8302 5988
Fax : +86 769 8302 5982
Email: info@tetleysprings.com
Web: www.tetleysprings.com

中國廣東省東莞市橋頭鎮石水口村銀河工業區（郵編：523528）
Qiao Tou Town ,Dong Guan City,Guang Dong Province,China (PC)523528

- **順德辦事處 (Shunde Office)**

Tel : +86 757 2211 2171
Fax : +86 757 2211 2172

佛山市順德區均安鎮牛仔城39號二座302室
Niuzai Cheng, Junan town, Shunde district,
Foshan, GuangDong, P.R.C